

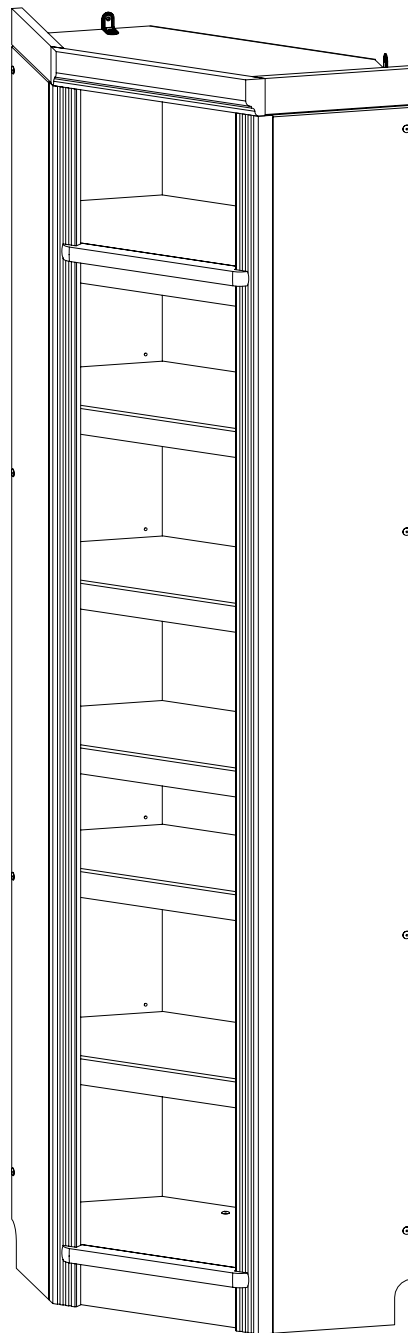

431155  
Art. 233697  
214583

LKZ 41332

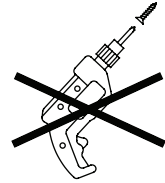
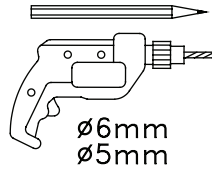
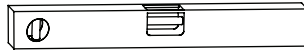
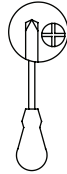
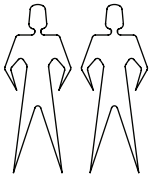

Teil Nr. Pièces Nr. Pieces No. Часть Ном. Kawalek Nr. Parça No Kusù Nr. Kusov Nr. Pezzi Nr. Nr piese. Darab száma. Stukken Nr. Kārtas nr.	Anzahl Quantité Quantity Количество Ilość Miktar Množství Množstvo Quantità Cantitatea Mennyiség Hoeveelheid Skaitis	Kasten Nr. Colli Nr. Colli No. Коробка Ном. Polu Nr. Kutusu Nr. Kolonka Č. Počet balení Colli Nr. Nu pachete Colli száma. Colli Nr. Kastes nr.	Maß, mm Dimensions, mm Dimensions, mm Размеры, mm Wymiary, mm Boyutlar, mm Rozměry, mm Rozmery, mm Dimensioni, mm Dimensiuni, mm Méterek, mm Afmetingen, mm Izmēri, mm	
1	1	2/2	2126 x 298 x 18	
2	1	2/2	2126 x 298 x 18	
3	1	1/2	728 x 340 x 25	
4	1	1/2	370 x 80 x 18	
5	1	1/2	728 x 322 x 18	
6	5	1/2	370 x 45 x 18	
7	1	1/2	2046 x 240 x 18	
8	1	2/2	2046 x 240 x 18	
9	4	2/2	725 x 322 x 18	
10	1	1/2	728 x 340 x 25	
11	1	1/2	779 x 375 x 65	
12	1	1/2	370 x 45 x 18	
15	2	1/2	364 x 35 x 25	
16	1	1/2	140 x 80 x 18	
72	1	1/2	1180 x 438 x 4	
73	1	1/2	880 x 438 x 4	

11066/5

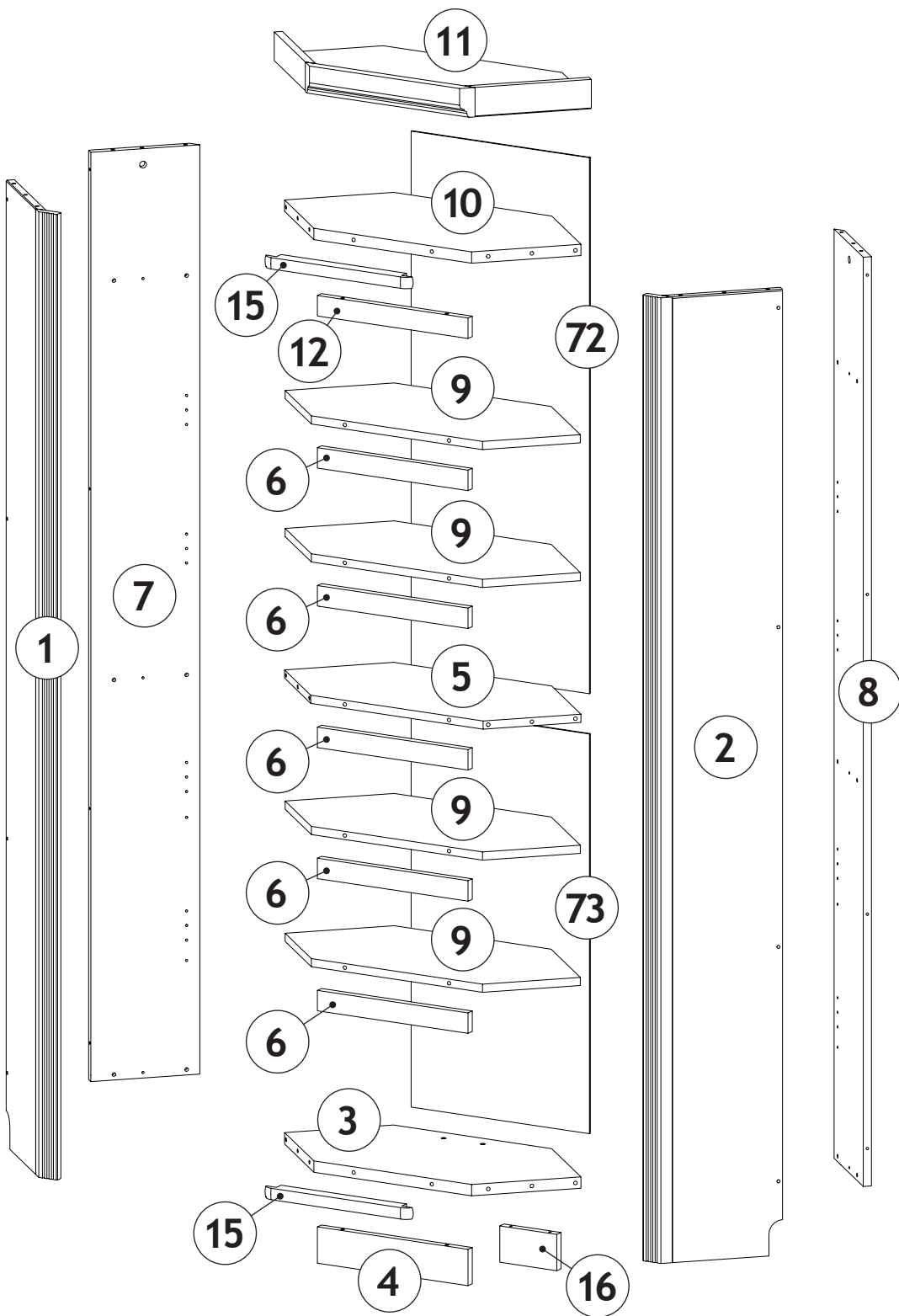

**Service • Assistenza • Dienstverlening • Serwis  
Servis • Szerviz • Сервисная служба**

Name • Nom • Nome • Naam •  
Nazwa • Jméno • Názov • Név  
Denumire • Isim • Название

Nr • No • N • Номер • Ć • Sz

Tур • Type • Tip • Típus • Tíro • Тип

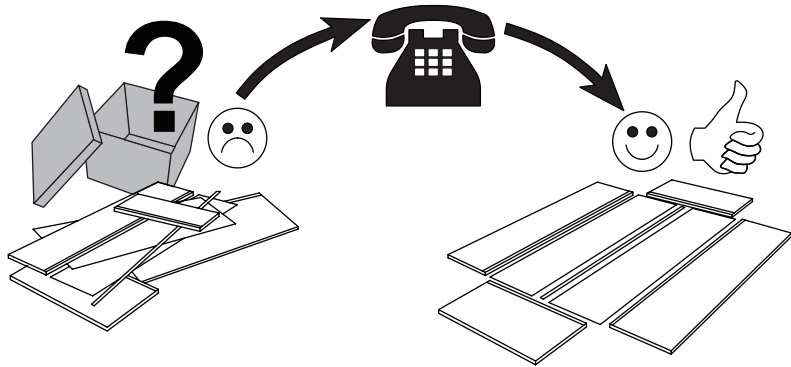
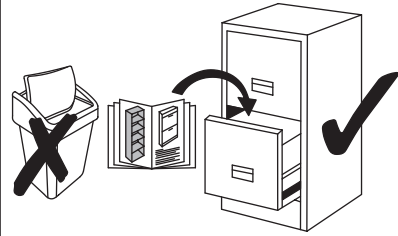

**H1**  
**(x32)**



**D5**  
**(x22)**



**D53**  
**(x12)**



**D2**  
**(x34)**



**D4**  
**(x24)**



**D24**  
**(x10)**

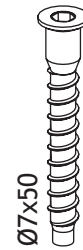

**A27**  
**(x10)**

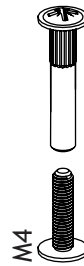

**A176**  
**(x2)**



**A4**  
**(x48)**



**D1**  
**(x24)**

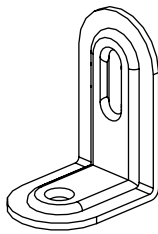

**D28**  
**(x2)**



**H12**  
**(x2)**

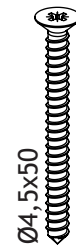

**A61**  
**(x2)**



**A1**  
**(x2)**

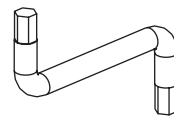

**A5**  
**(x1)**

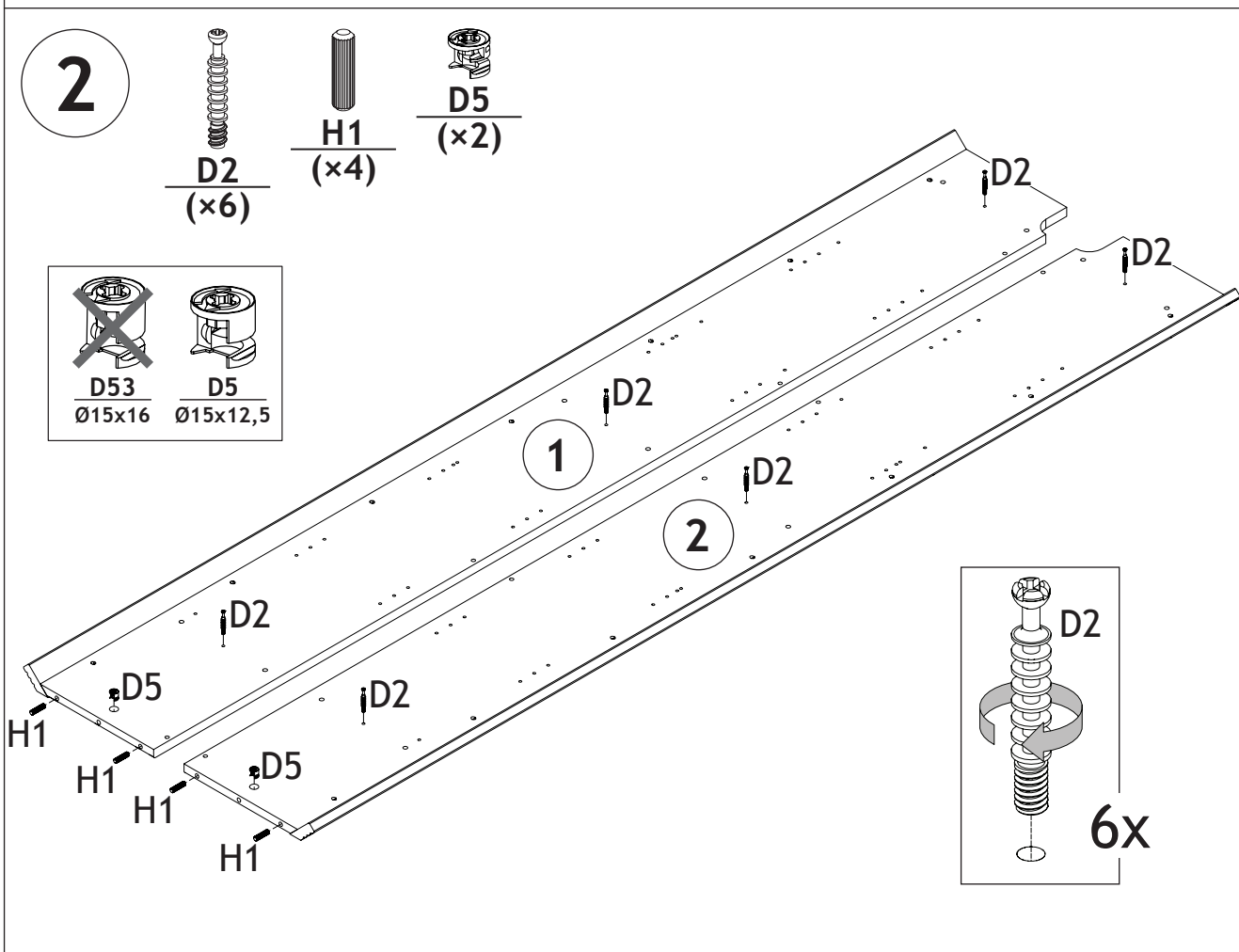
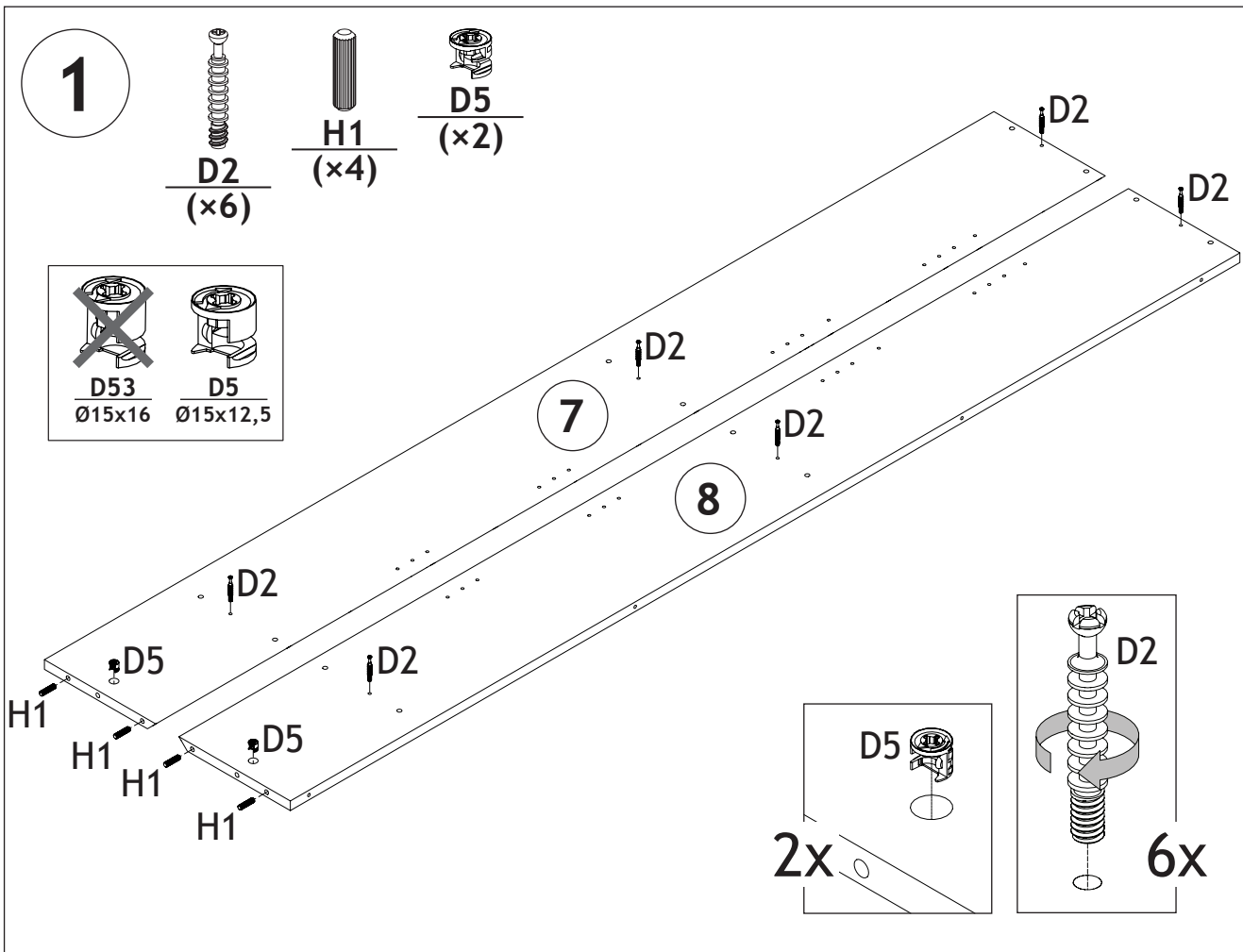

3

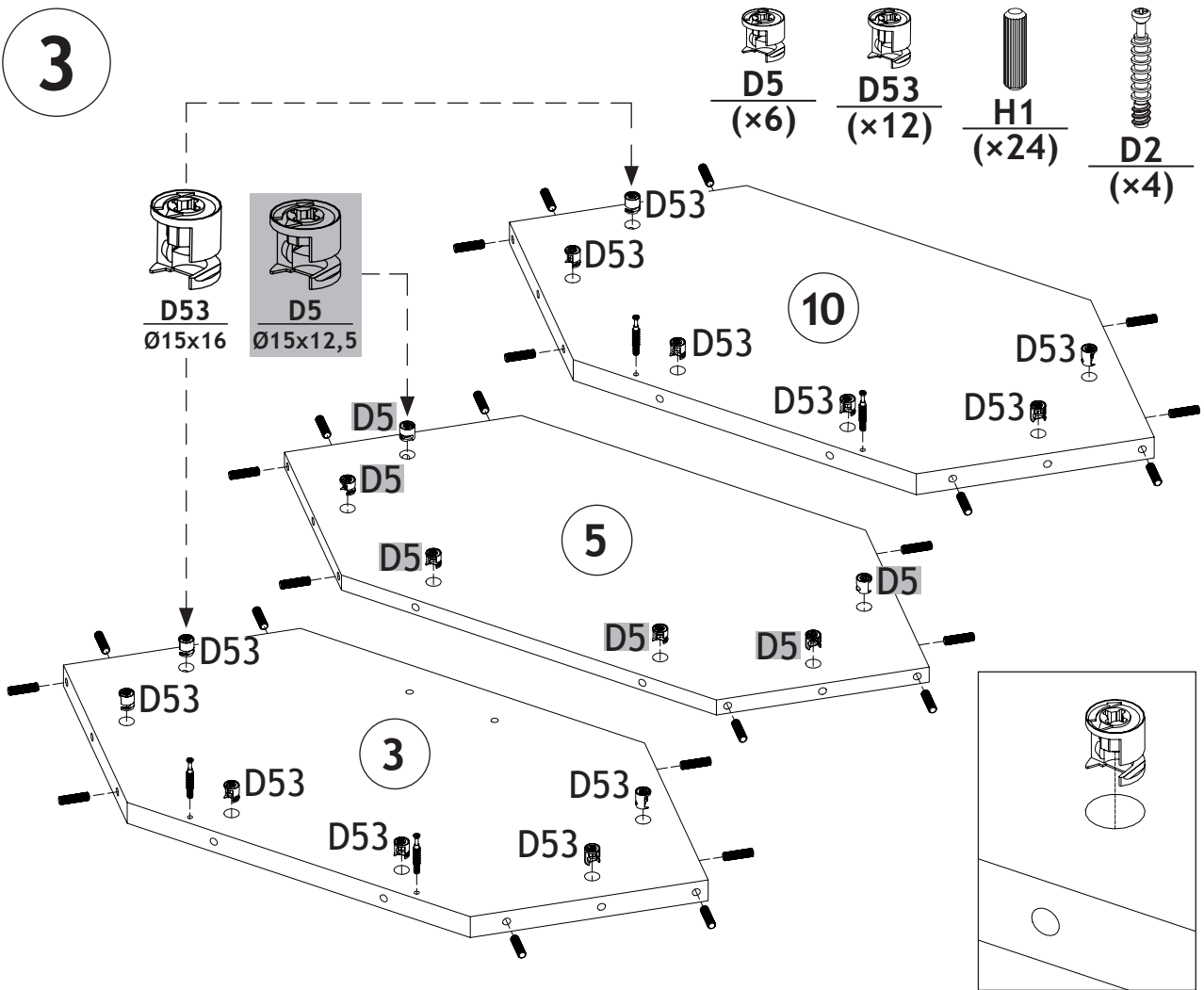

4

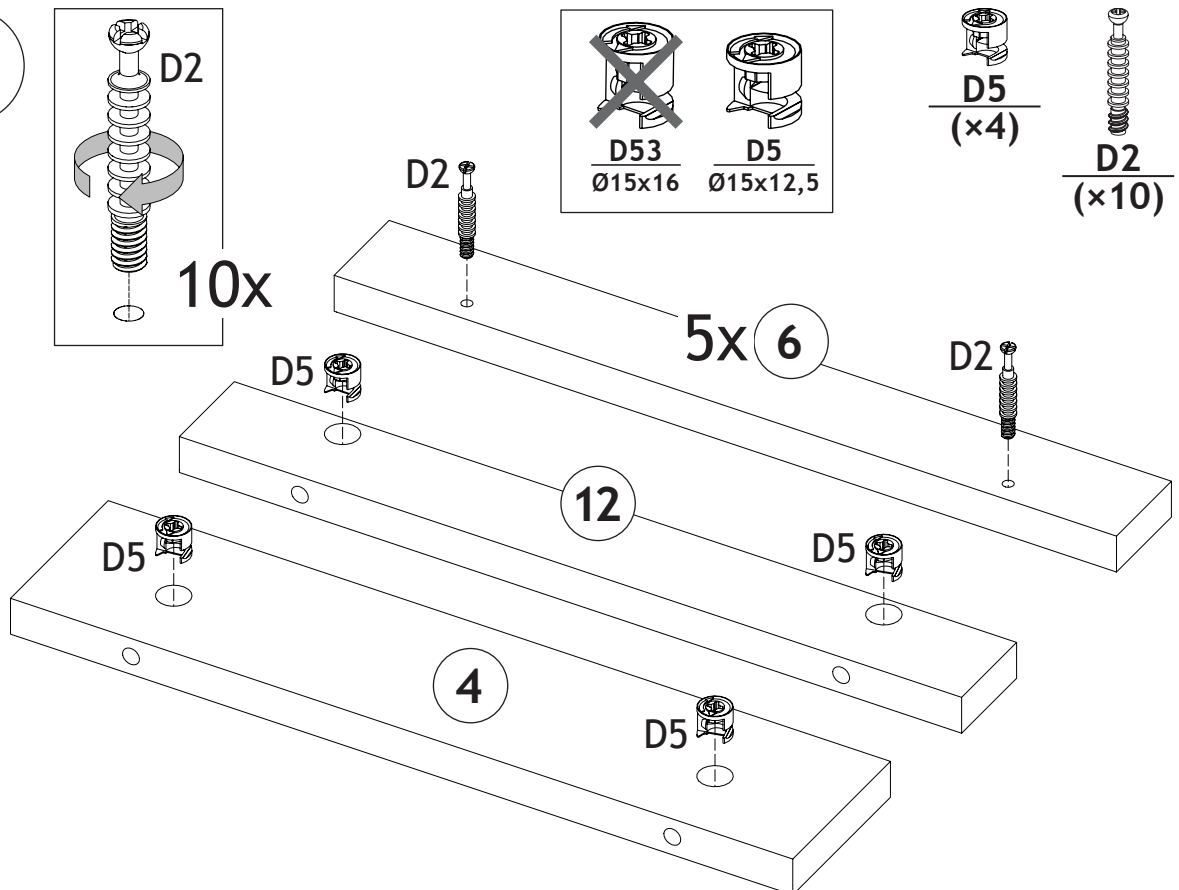

5

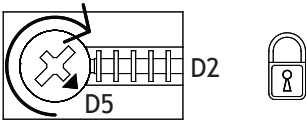
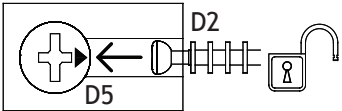
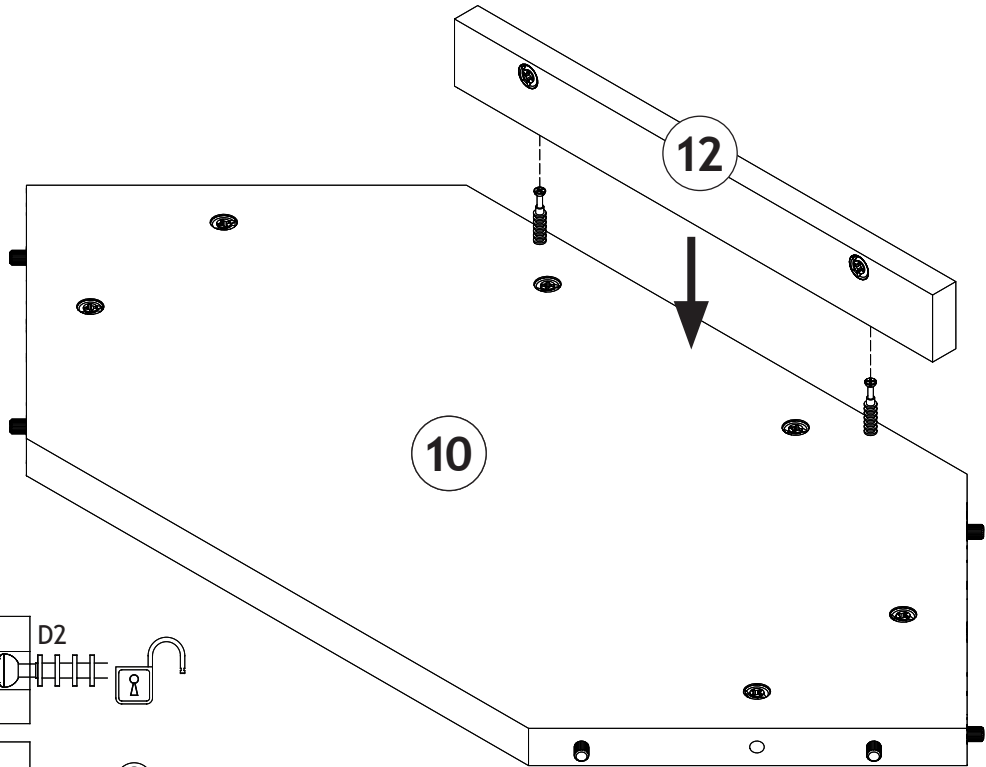

6

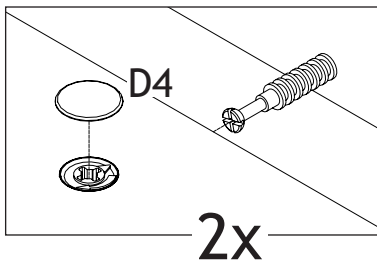

$\frac{D4}{(\times 2)}$

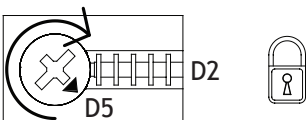
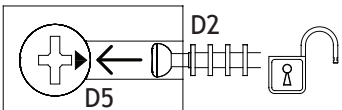
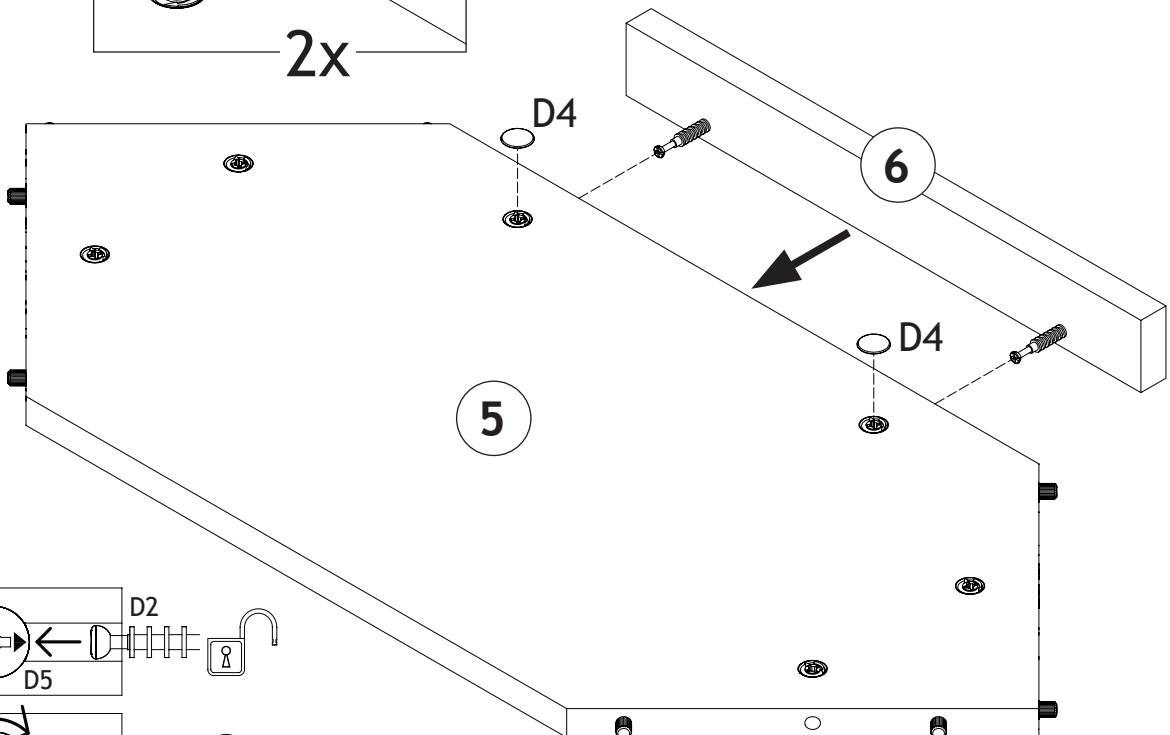

7

A27  
(x2)

A5  
(x1)

D24  
(x2)

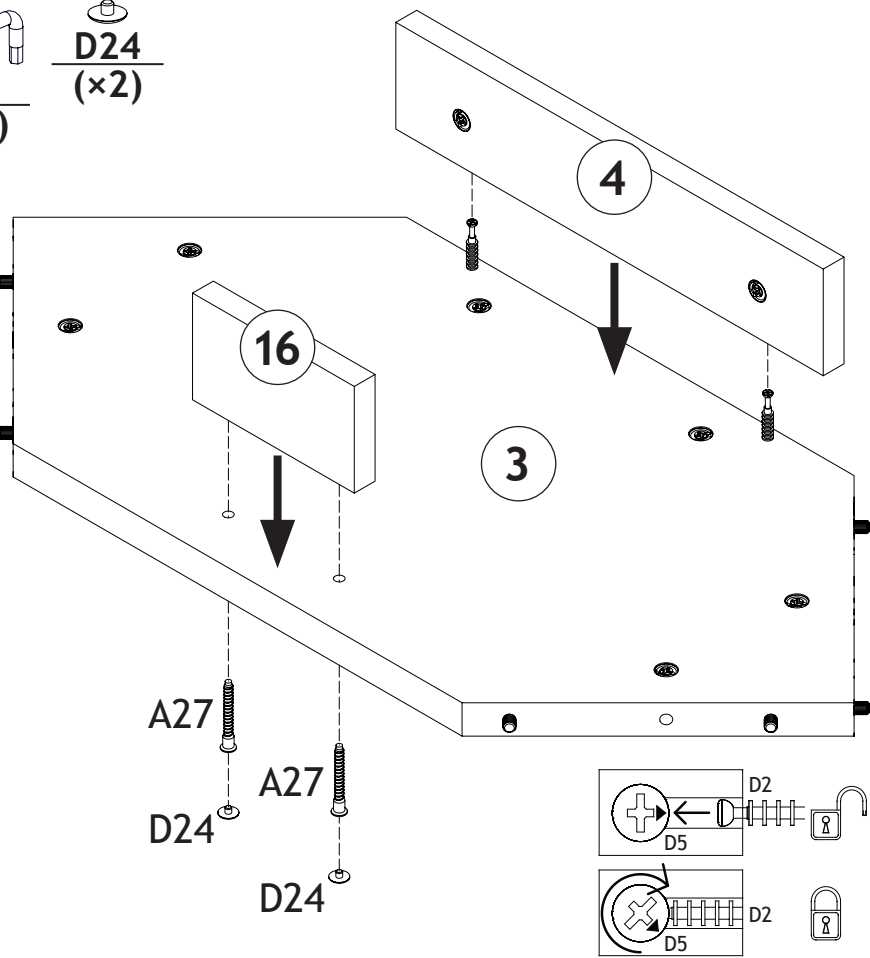
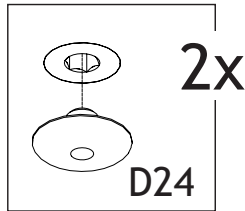
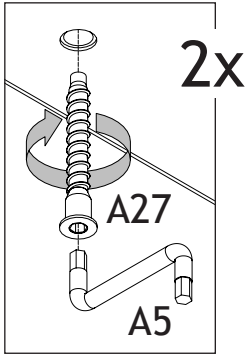

8

~~D53~~  
Ø15x16

D5  
Ø15x12,5

D5  
(x8)

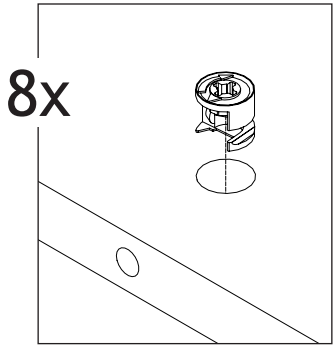
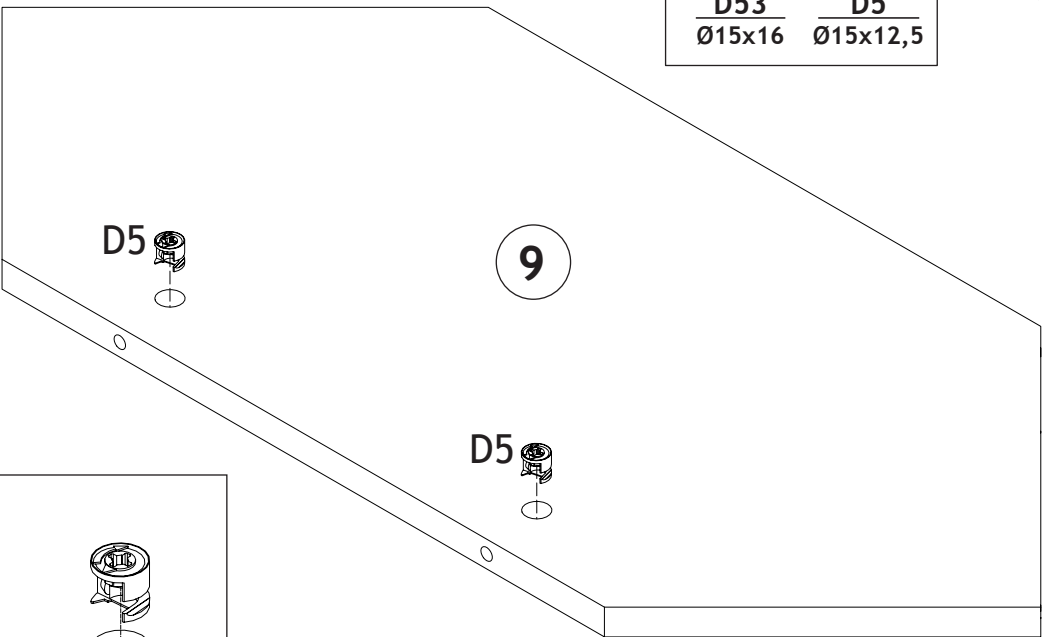

4x

11066/5



9

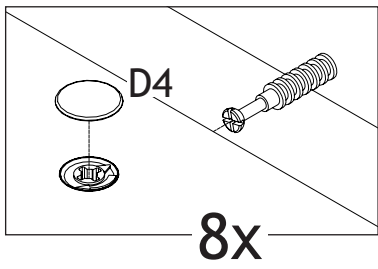

D4  
(x8)

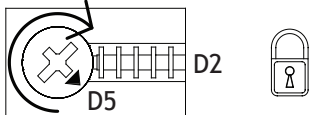
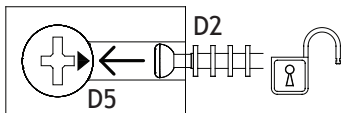
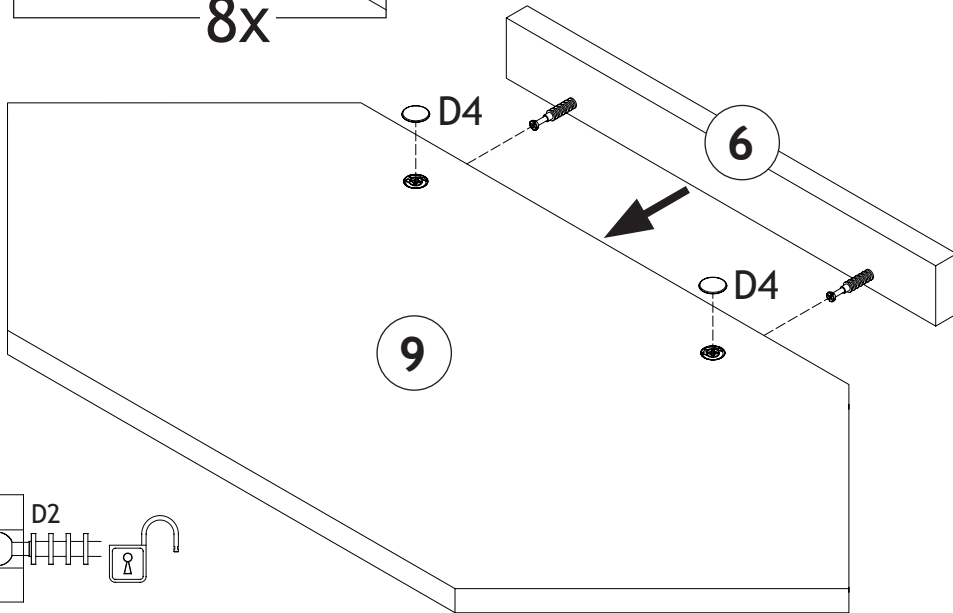

4x

10

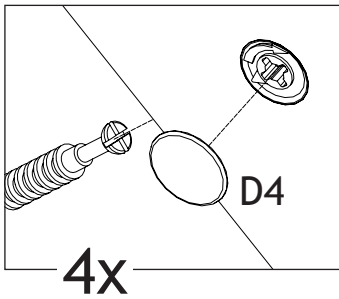

D4  
(x4)

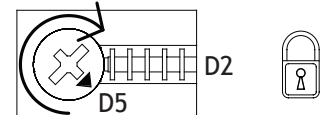
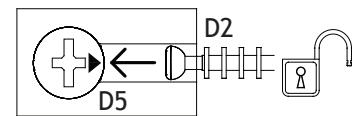
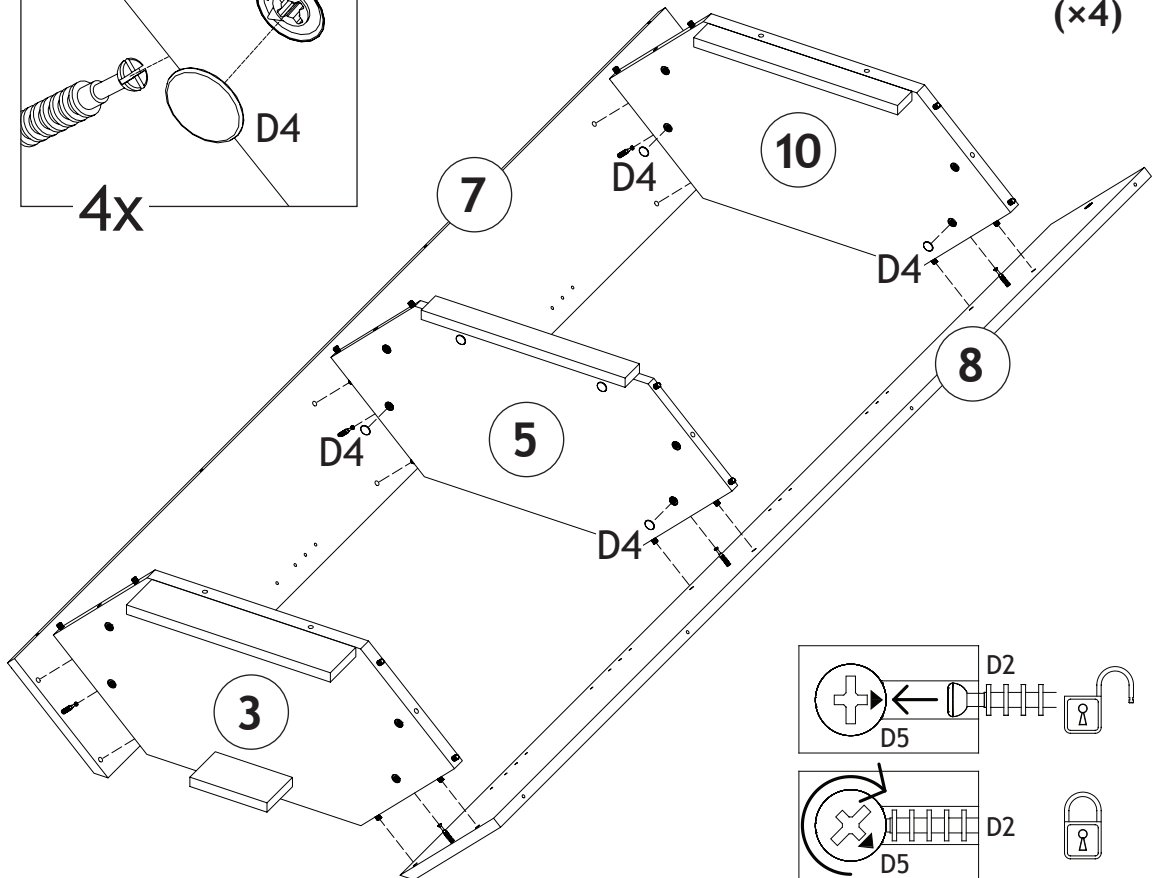

11066/5

11

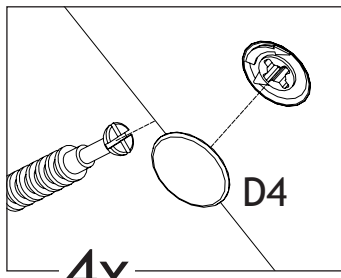

4x

D4  
(x4)

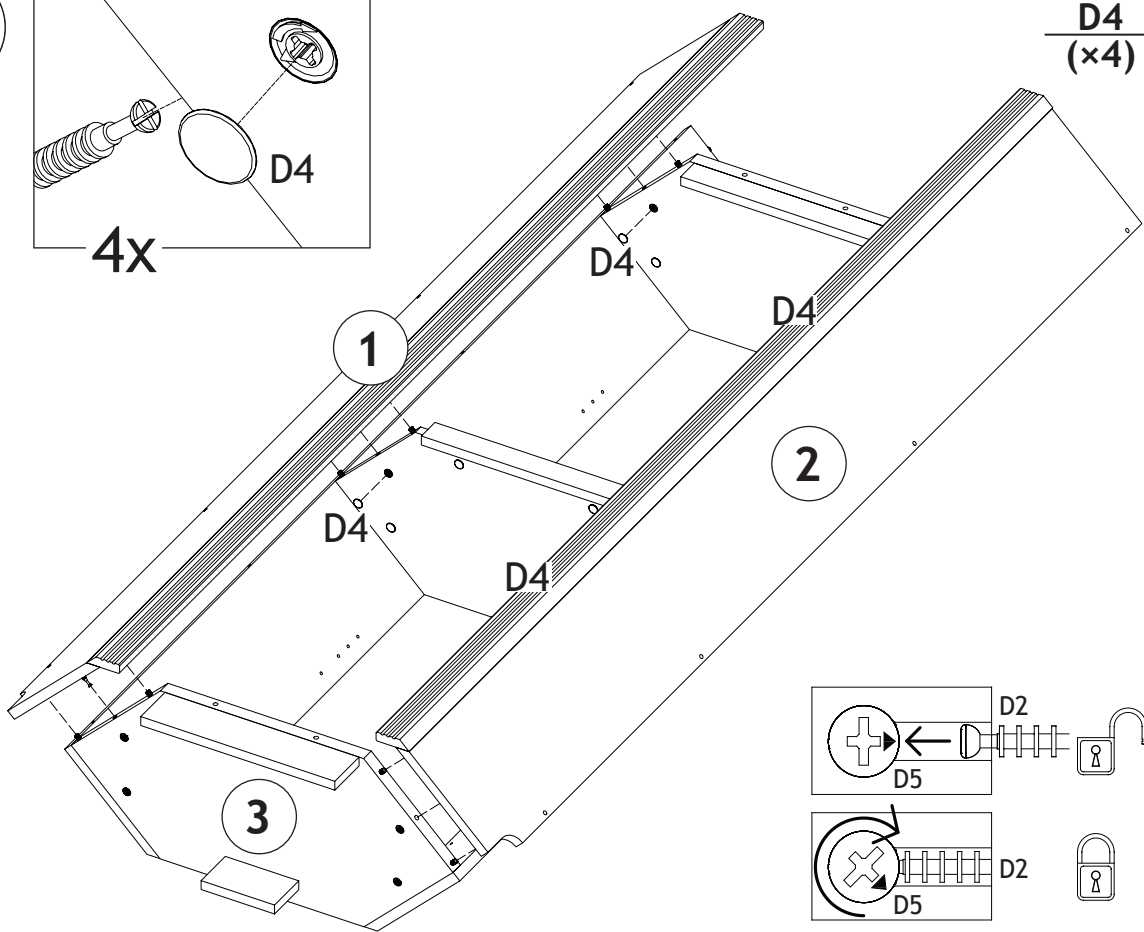

12

D2  
(x4)

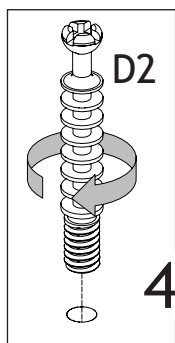
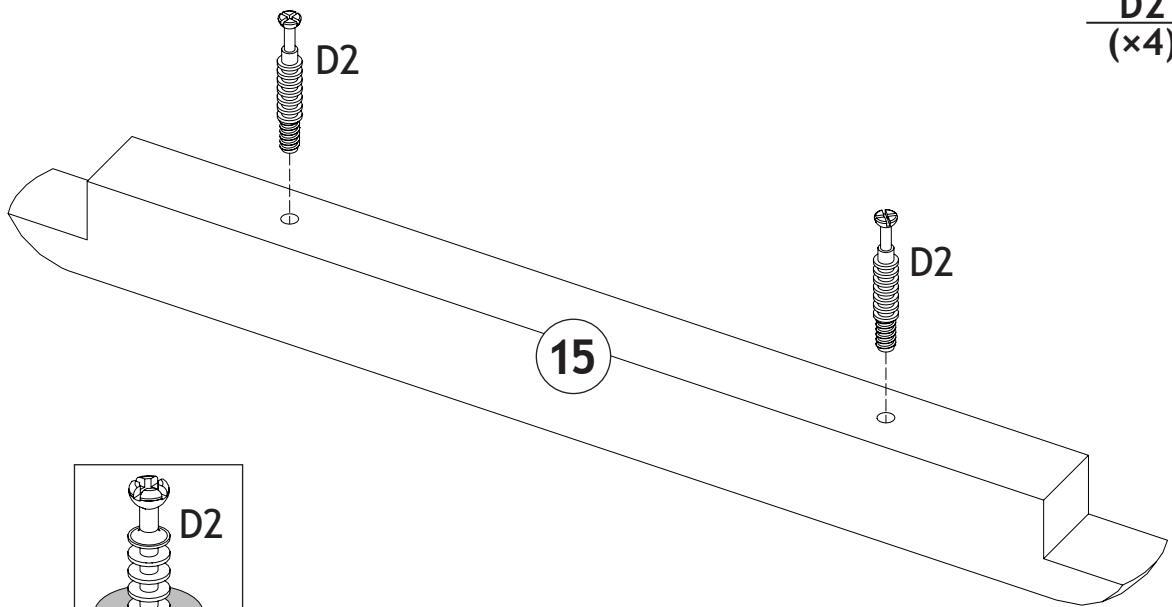

4x

2x

11066/5

13

A27  
(x8)

A5  
(x1)

D24  
(x8)

D4  
(x2)

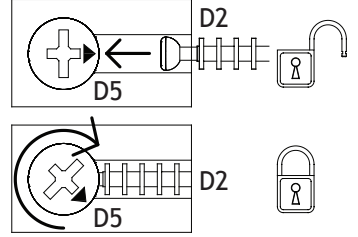
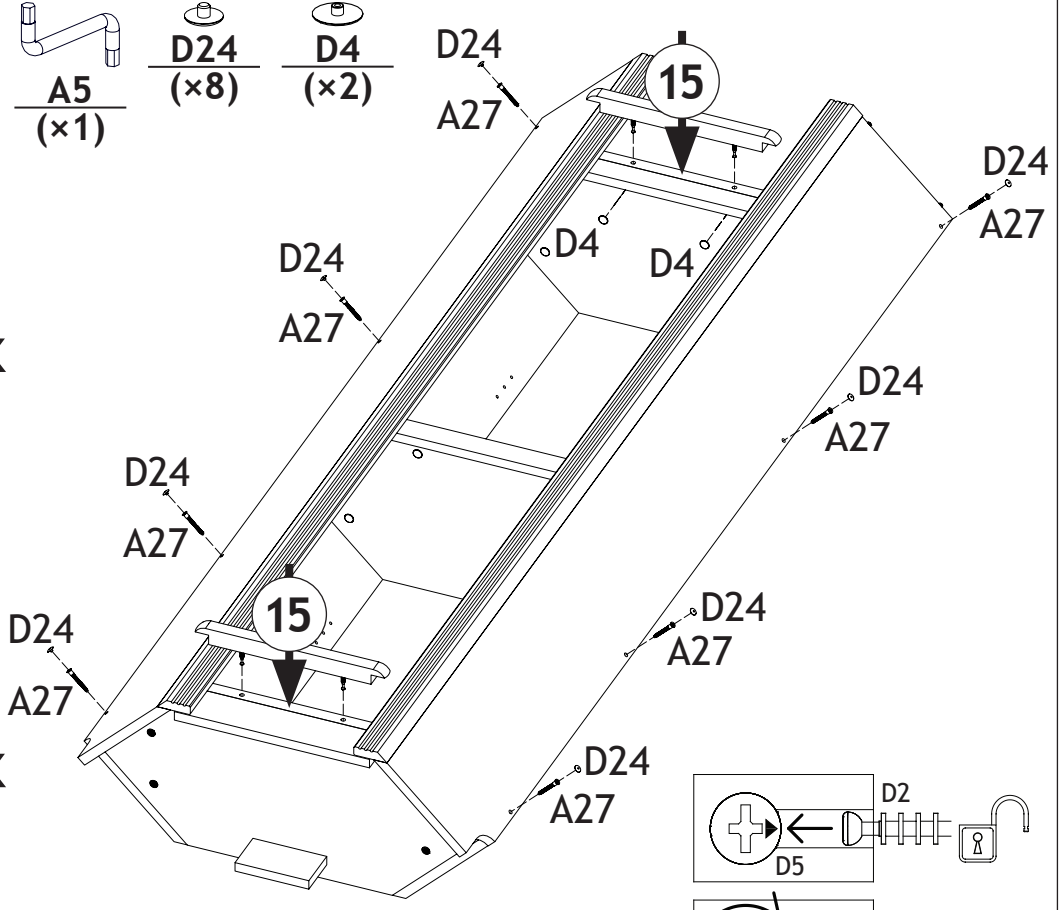
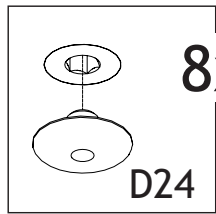
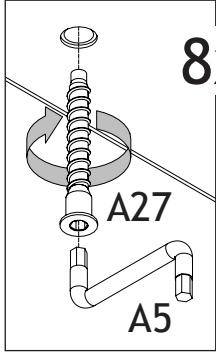

14

D2  
(x4)

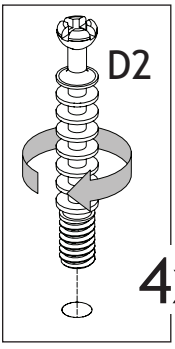
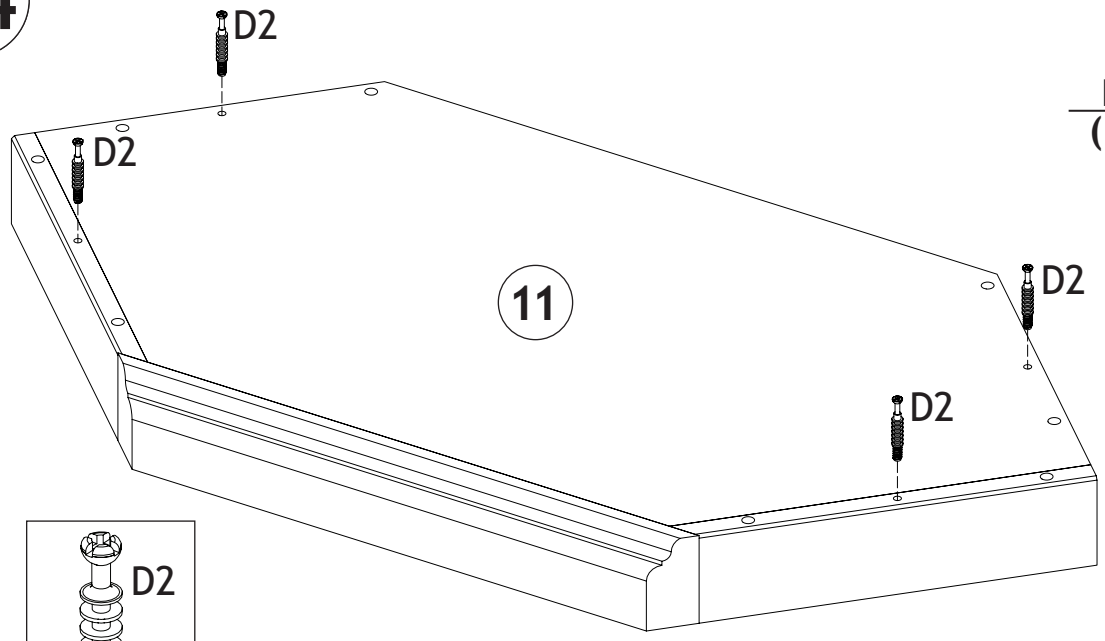

11066/5

15

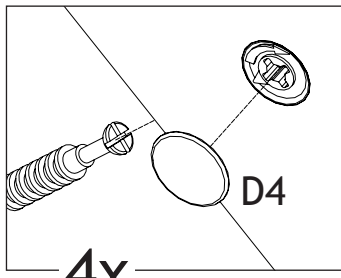

D4  
(x4)

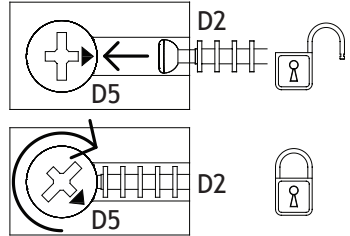
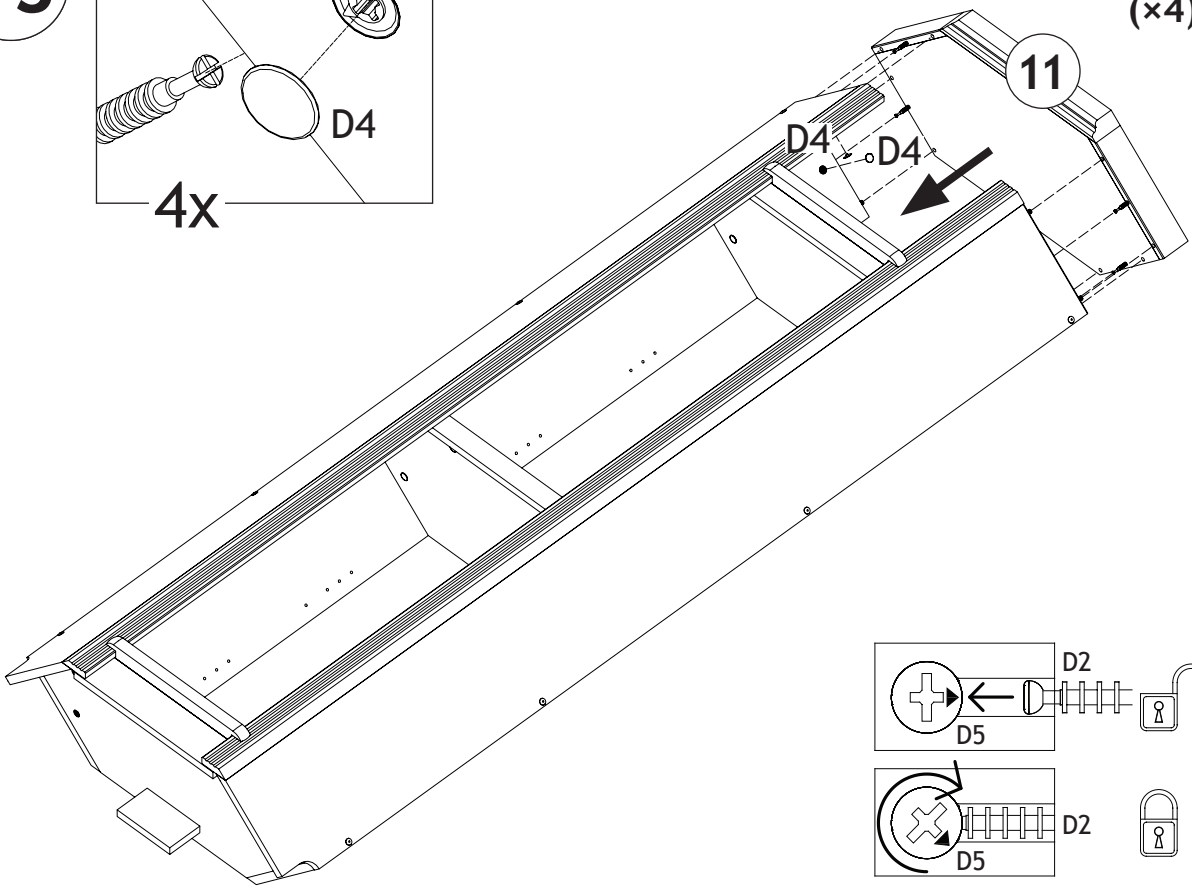

16

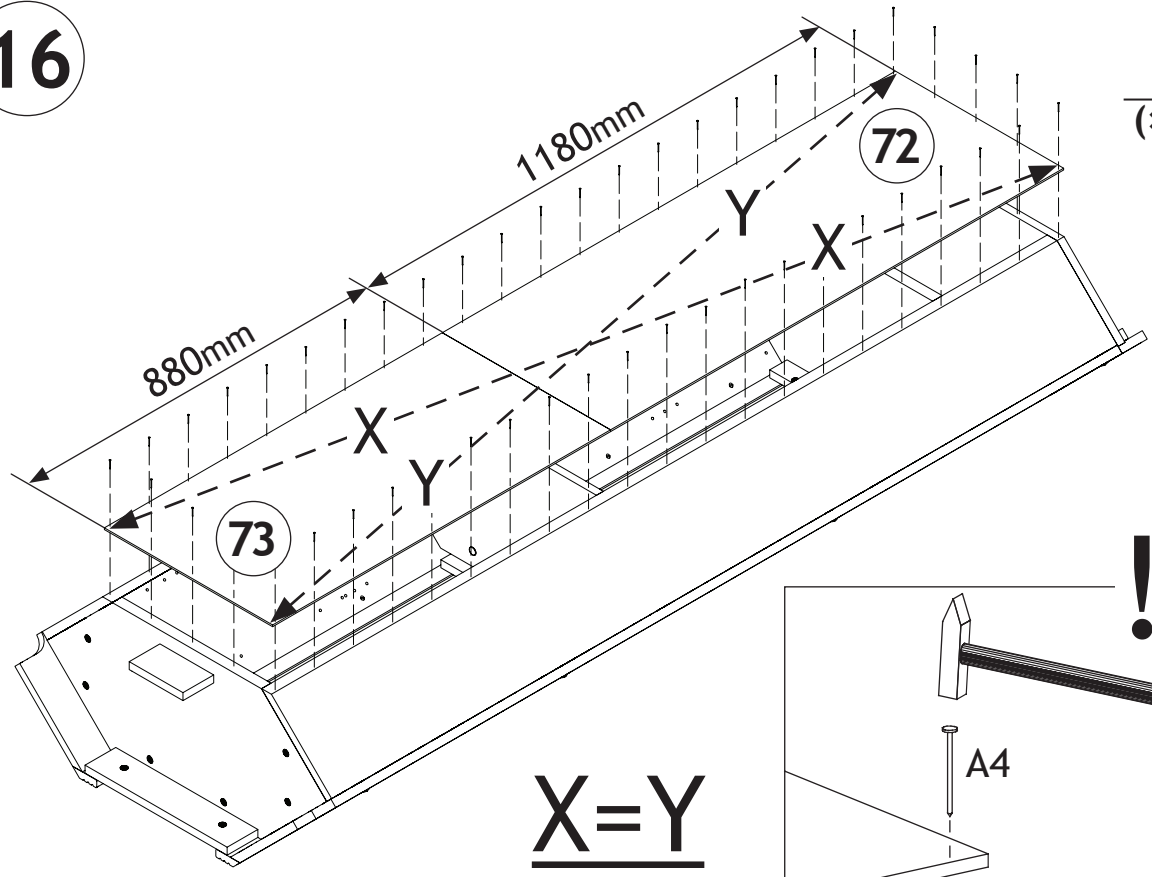

A4  
(x48)

X=Y

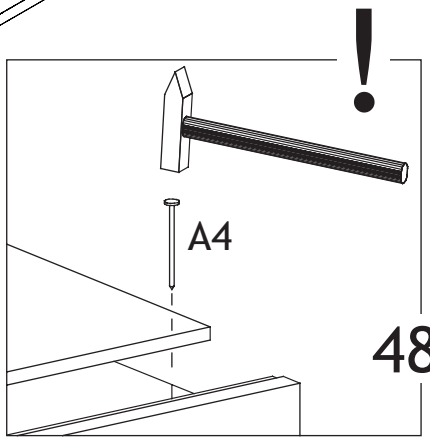
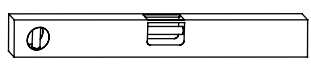

48x

11066/5

17

A61  
(x2)

H12  
(x2)

D28  
(x2)

A1  
(x2)

D1  
(x24)

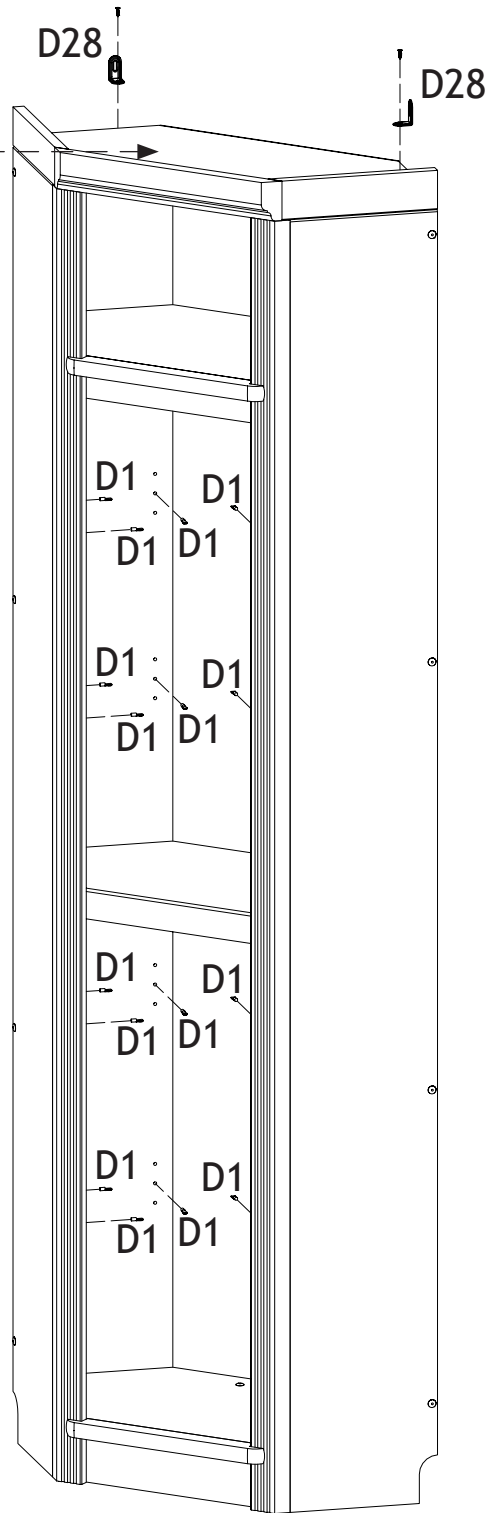
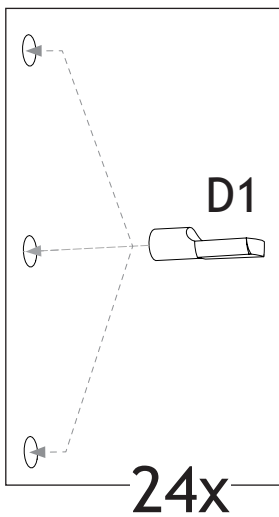
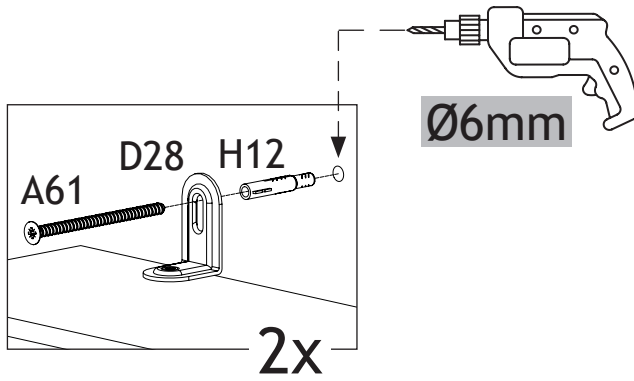
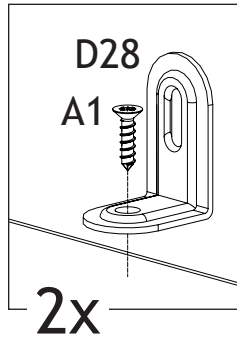

11066/5

18

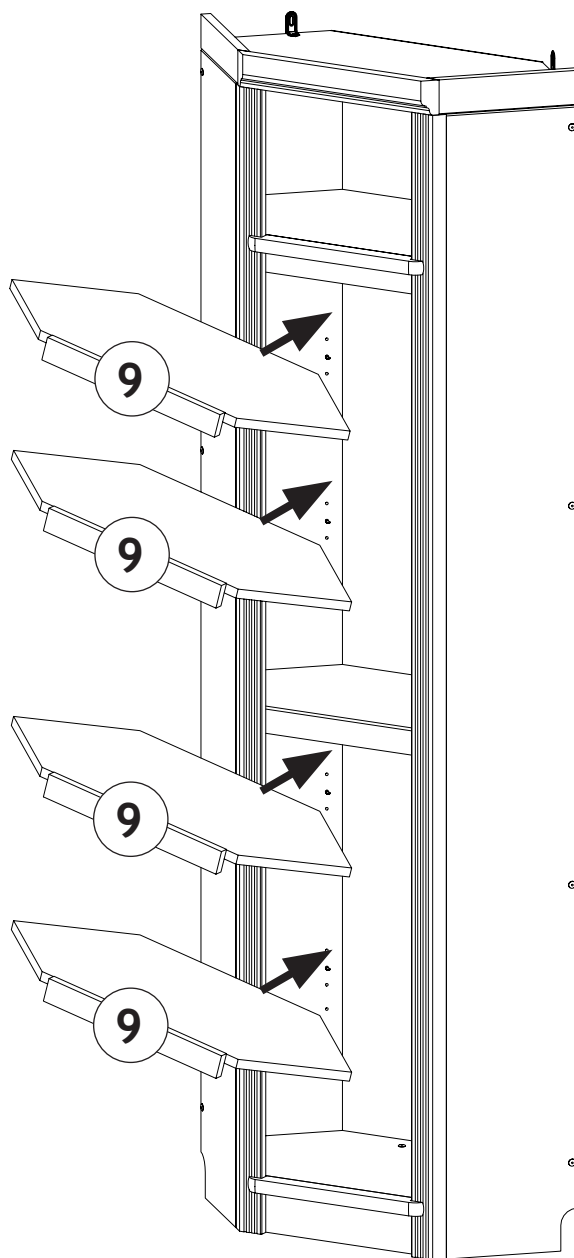

19



  
**A176**  
**(x2)**

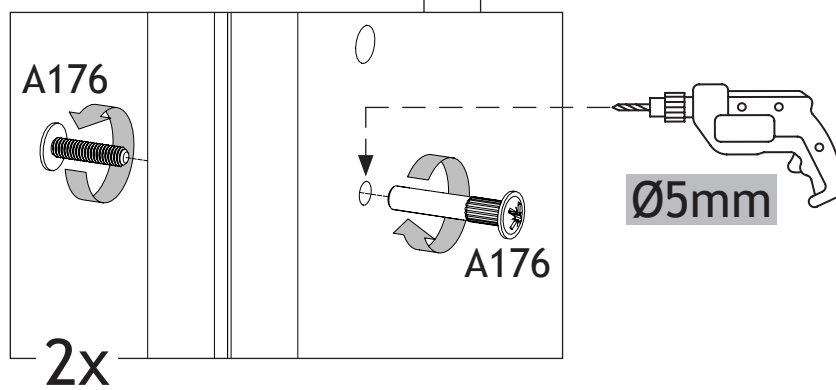

11066/5

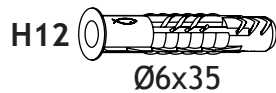

 Ø6mm

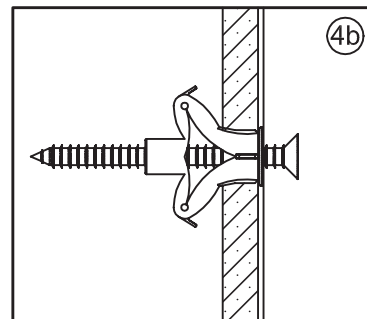
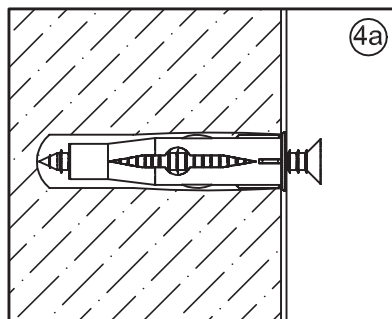
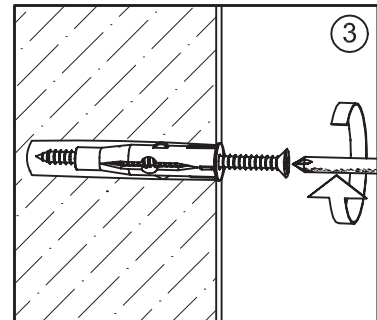
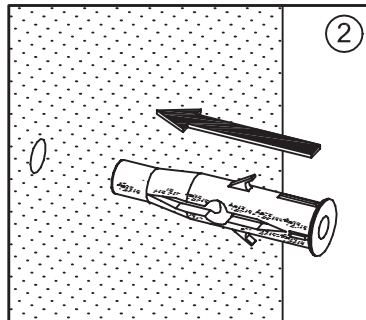
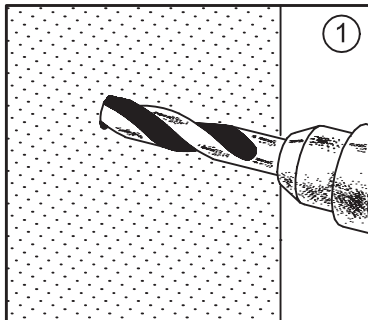

- D** **Achtung:** Die Befestigung des Möbelstückes an der Wand muss von einer fachkundigen Person vorgenommen werden, da für die Montage an die Wand angepasste Dübel erforderlich sind.
- GB** **Attention:** A qualified professional is required when mounting furniture to the wall since dowels corresponding to the wall are required for this.
- FR** **Attention:** La fixation du meuble contre le mur doit être effectuée par une personne compétente car, pour le montage mural, il faut utiliser des chevilles adaptées.
- IT** **Attenzione:** Il fissaggio del mobile alla parete deve essere eseguito da persone esperte, dato che occorrono tasselli adeguati.
- NL** **Opgelet:** een vakkundige persoon dient het meubelstuk aan de muur te bevestigen; voor de montage aan de muur zijn immers aangepaste pluggen vereist.
- PL** **Uwaga:** Mocowanie mebla do ściany mogą przeprowadzić wyłącznie wykwalifikowane osoby, z uwagi na zastosowanie odpowiednio dopasowanych kołków do rodzaju ściany.
- CZ** **Pozor:** Montáž nábytku na stěnu musí provést odborník, protože k montáži na stěnu jsou zapotřebí upravené hmoždinky.
- SK** **Pozor:** Upevnenie nábytku na stenu musí vykonať odborník, nakoľko súpre montáž na stenu potrebné vhodné hmoždinky.
- HU** **Figyelem:** A bútorelemek falra rögzítését szakembernek kell végeznie, mert a rögzítéshez megfelelő tiplit kell használni.
- RO** **Atenție:** Fixarea la perete a piesei de mobilier se realizează numai de către personal competent, deoarece montajul de perete necesită dibluri adecvate.
- TR** **Dikkat:** Mobilya parçasının duvara sabitlenmesi, duvar montajı için özel uyarlanmış dübeller gerektirdiğinden bu iş sadece bu konuda uzman bir kişi tarafından gerçekleştirilmelidir.
- RU** **Внимание:** Поскольку для монтажа на стене необходимо использовать специальные дюбели, мебель должна быть закреплена на стене квалифицированным персоналом.